

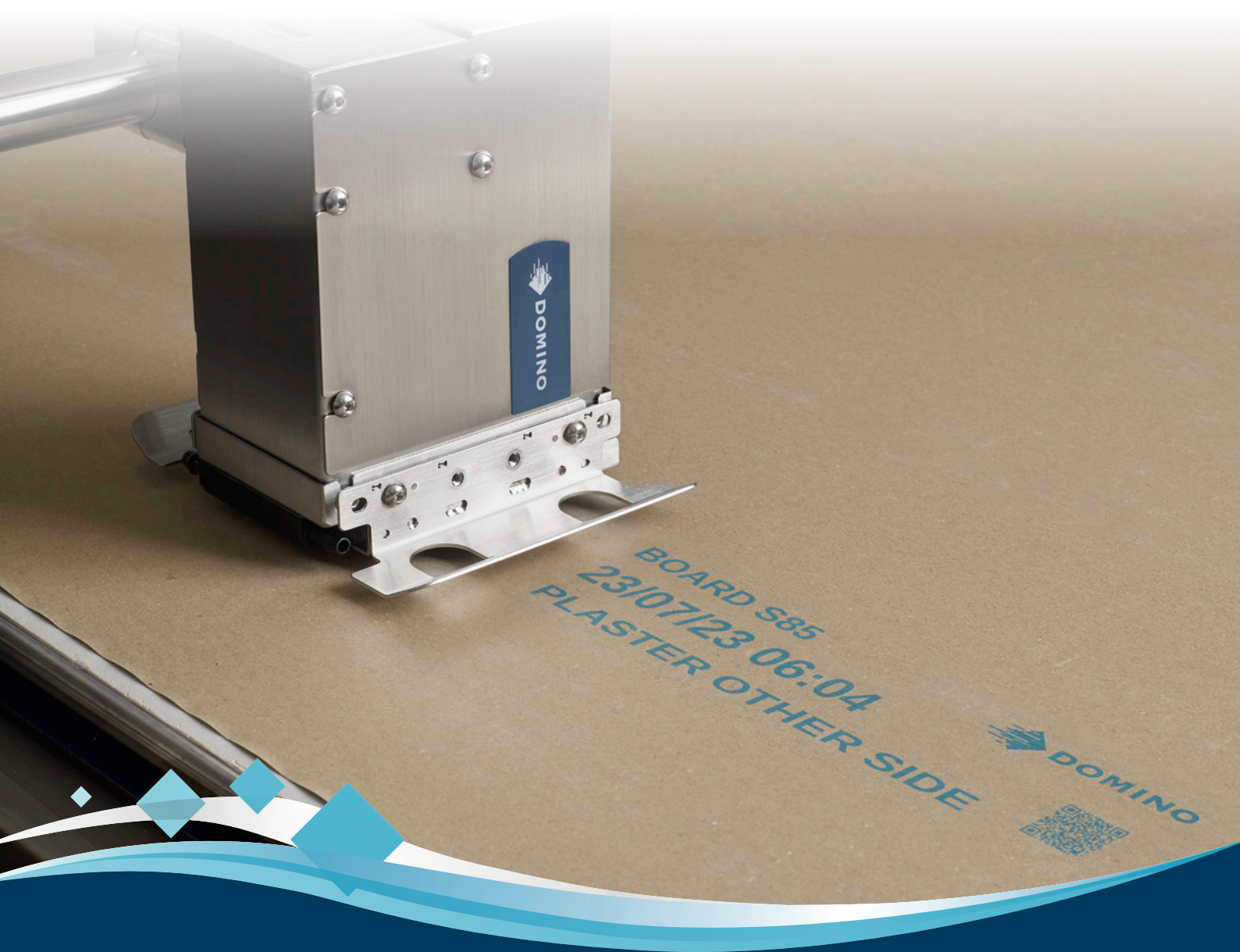

Cx350i Industrial Printer

Codes without compromise

Large format, high-resolution printing for construction materials manufacturers



Domino. Do more.

Speed without compromise

The **Cx350i** industrial printer delivers large format, high-resolution printing without compromising production line speeds



Capable and dependable

The Domino **Cx350i** industrial printer offers an unparalleled combination of large format, high-quality printing, in a machine capable of true industrial line speeds (100m/min.+). It can produce graphics and logos, text using true-type fonts (including real-time data), and machine-readable codes – in any size and combination. Individual printheads achieve 65mm print height, and multiple printheads can be combined for even greater print areas.

The large volume ink reservoir is easily replenished, without the risk of ink spillages and without interrupting production. Domino's intuitive **QuickStep** user interface minimises the need for extensive operator training and reduces the risk of errors. The system doesn't require scheduled maintenance, and operates without the need for factory air.

The **Cx350i** industrial printer has single-colour printing capability, with four colour options available.



Green Credentials

Domino is committed to minimising the consumption of natural resources, energy, and the creation of waste. The Domino **Cx350i** can significantly reduce your environmental footprint. No factory air needed. No label waste, only vegetable-oil-based inks delivered in small drops to make great codes.

Connectivity without compromise

The printer's performance can be remotely monitored 24/7, thanks to **Domino Cloud**. The online dashboards provide operational insight, allowing you to maximise production efficiency. Automatic alerts can be sent to notify when intervention is required – or if faults are detected. And if you need our support, then remote access from our helpdesk engineers helps us to help you.

The **Cx350i** industrial printer comes with multiple options for connectivity for added flexibility. The printer can connect to label creation packages, such as NiceLabel™ and Domino Designer, and to your factory MES and ERP systems, via Domino Automation. Our Dynamark command protocol provides seamless integration into bespoke factory software systems. EtherNet/IP is a standard option.



Support without compromise

As a truly global business, Domino is able to offer worldwide helpdesk and field service support. Working to common standards the world over, our engineers are there to support you in achieving your commercial goals. Access to this support is available to all our customers, while a range of service and support contracts offer peace of mind and predictable costs.

A complete solution

Our services are designed to provide operational resilience, helping you to reduce downtime and maximise production efficiency.



Operational support

An outstanding level of care, wherever you are. Our **SafeGuard** packages provide high-quality, on-site assistance and AR-enabled remote guidance from our technical experts. **SafeGuard** helps to ensure we can be with you when you need us most.

Automatic code inspection

Ensure every code that leaves your factory is present and correct. With the R-Series – Domino's range of vision control systems – you can automate your code inspection to validate code presence, placement and readability, and free up operator time for other activities.

Control software

Minimise errors using Domino's **QuickDesign** software. Control your product codes from a central location and streamline product changeovers. **QuickDesign** uses standard communication protocols and can be integrated into existing ERP systems.

Smart production

Gain operational insight by connecting your printer to **Domino Cloud**. Obtain production analytics dashboards and receive system error alerts by phone or email. **Domino Cloud** provides you with the information you need to run your operations more efficiently.

Technical specification

Cx350i

Base units	Cx-Inkbase 2PH Printheads (max.) 2 Internal ink reservoir 440ml	Cx-Inkbase 4PH Printheads (max.) 4 Internal ink reservoir 760ml
Dimensions	Width 329.7mm / Depth 233.7mm (252.7mm with mounting bracket) / Height 489.5mm Not including power button, latch, connector cover, bracket Weight Cx-Inkbase 2PH: 13.55kg, Cx-Inkbase 4PH: 15.03kg	
Electrical supply	Input: 100-240VAC, 50-60 Hz, Cx-Inkbase 2PH: 2A, Cx-Inkbase 4PH: 3A	
External connection options	1 x encoder input, 1 x I/O connector (4 x product detect sensors I/P, 5 x general purpose I/P, 8 x general purpose O/P, 3 x 24VDC O/P), 2 x USBs (type A), 1 x RS232C, 2 x RJ-45	2 x encoder inputs, 2 x I/O connectors (4 x product detect sensors I/P, 9 x general purpose I/P, 12 x general purpose O/P, 4 x 24VDC O/P, 3 x alarm contacts), 2 x USBs (type A), 1 x RS232C, 2 x RJ-45
Printhead		
Dimensions (remote head)	Width 85.9mm / Depth 173.4mm / Height 130.2mm / Weight 1.73kg Conduit length 0.5m, 1.5m, 3.0m & 4.5m options	
Dimensions (remote head header tank)	Width 179.2mm / Depth 164.4mm / Height 121.8mm / Weight 2.27kg	
Electrical supply	24VDC (supplied from the inkbase unit)	
Resolution	Horizontal max. 300dpi, vertical 150dpi	
Print height	65mm max.	
Touchscreen		
User interface	Touchscreen 10" with QuickStep 3 software	
Dimensions	Width 320.0mm / Depth 45.0mm / Height 235.0mm / Weight 2.65kg	
System specification		
Operating temperature	5-40°C	
Operating relative humidity	10-90% RH (non-condensing, 10°C increase per hour)	
Finish (printhead and base unit)	Brushed stainless steel	
Protection printhead and inkbase	IP4X	
Inks*	High-contrast, vegetable-oil-based inks available in 1.4 and 0.85 litre bottle sizes	
Communication	Ethernet/Dynamark protocol, EDC (serial, TCP, USB), optional: Ethernet/IP™ protocol Domino Cloud Interface (DCI), Domino coding automation	
Print speed	max. 210m/min. @100dpi, 100m/min. @200dpi, 70m/min. @300dpi	

*This product has a Quality Management System that means that it will only work with Domino circuitry, and it uses dynamic security measures to block non-Domino circuitry from being used. From time to time updates to the circuitry will be issued by Domino to maintain the effectiveness of the Quality Management System.

Touchscreen

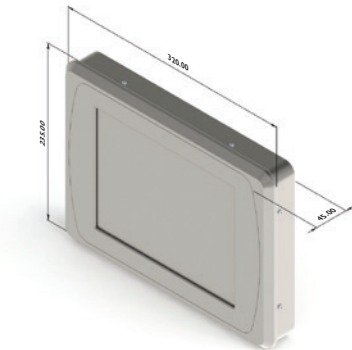

Base unit

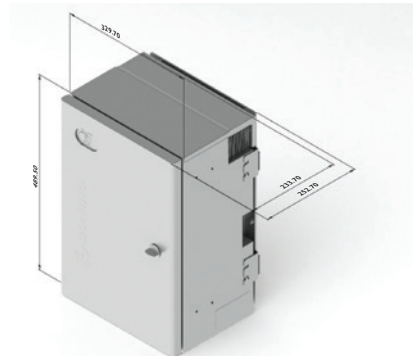

Remote printhead – vertical

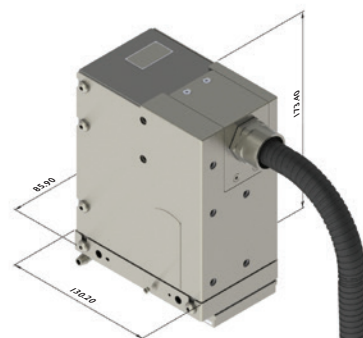

Remote printhead header tank

